

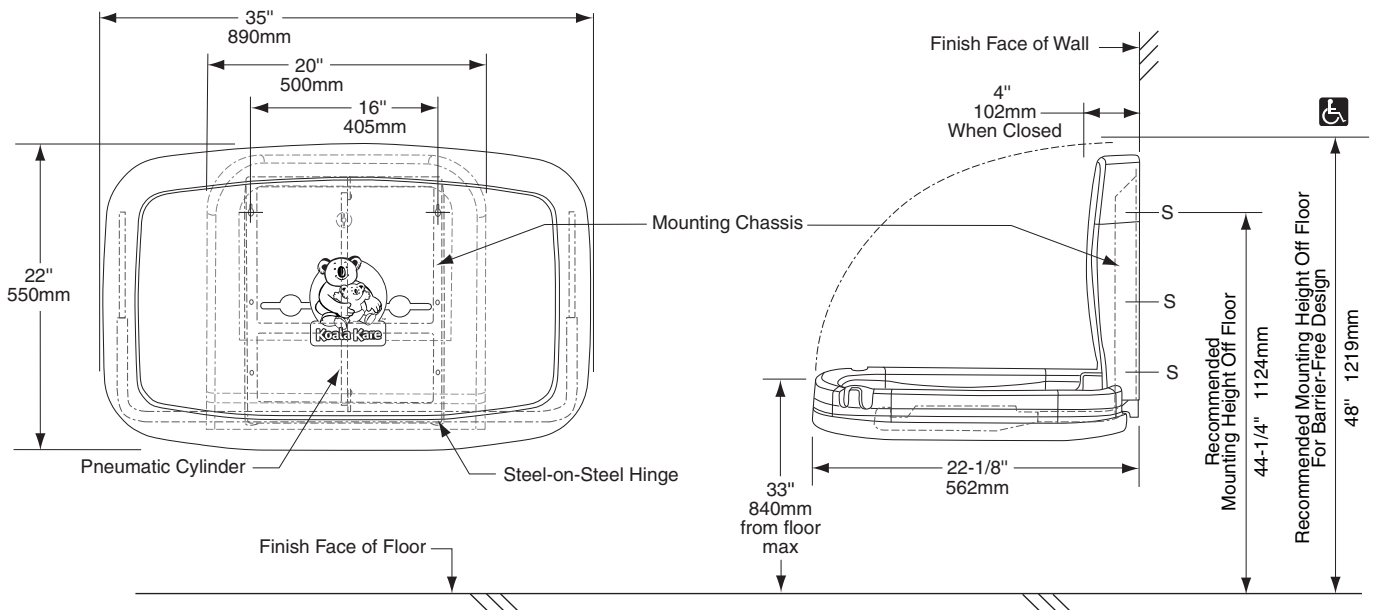

Koala Kare Products
A Division of Bobrick

HORIZONTAL WALL-MOUNTED BABY CHANGING STATION

KB200-00 CREAM



ADA Compliance

(when properly installed)

- 4.4.1 Max. Protruding Objects
- 4.2.5 Forward Reach
- 4.2.6 Side Reach
- 4.27.4 Operation

MATERIALS:

FDA approved injection-molded polypropylene with Microban® antimicrobial additive embedded into the bed surface. Reinforced steel-on-steel hinge mechanism and metal mounting chassis with mounting hardware included. Labeled usage instructions and safety messages in four languages. Optional Braille label available. Contoured changing surface area is 450 sq. in (11,430 sq. mm) and comes complete with nylon safety strap and bag hooks. Dual cavity liner dispenser holds approximately 50 KB150-99 bed liners.

continued . . .

OPERATION:

Concealed pneumatic cylinder and metal mounting chassis provides controlled, slow opening and closing of bed. Polypropylene is easy to clean and resists odors and bacterial growth. Complies with ASTM static load performance requirements when properly installed

Warning: *To ensure that the unit supports the intended loads, baby changing stations must be properly installed according to the manufacturer's instructions.*

INSTALLATION:

To ensure proper installation and compliance to building codes, it is recommended that a qualified person or carpenter perform the installation of the unit. The unit must be properly installed onto a permanent wall that is capable of supporting significant weight and can accommodate the supplied installation hardware. The Koala Baby Changing Station meets ADA regulations when properly installed.

Drilling holes and mounting the station:

1. Remove changing station from the shipping container and check for any freight damage. If damage is found, please call Koala Kare Products' Customer Service at 888.733.3456. Remove "Installation Kit" and "Operator Kit" from box. Please give "Operator Kit" to facility manager or operator. Box should contain two pieces: the bed and metal mounting chassis and the wall mount liner dispenser. Identify the best location for installing the unit.
2. Standard installation- Remove the bed and chassis from the box and select the wall area where the unit will be installed. Make sure you have taken into consideration the operating clearance of 9-1/2" (241.3mm) on both sides of the exposed chassis and 22" (558.8mm) from wall surface when open. Measure from the floor 44-1/4" (1123.95mm) on stud center and mark wall. The mounting holes are designed for 16" stud centers. Ensure the locations you have marked for the mounting holes are level before drilling. Drill pilot holes for keyhole mounting using a 1/8" regular drill bit.

Masonry or Tile over Stud Wall- Use a 7/32" (5.56mm) masonry drill bit for the pilot hole until you hit the stud. Change bit to 1/8" (3.18mm) regular drill bit.

Metal Stud or Concrete Block- If the wall has wood studs that are not on 16" (406.4mm) centers, has metal studs or an underlying surface on concrete block, drill with a 1/2" (12.7mm) masonry bit. (You may have to purchase toggles before installing.) You must allow a minimum of inside wall space for toggles to turn depending on toggles used. Insert and tighten toggles.

3. Screw two of the mounting screws into the pilot holes leaving 1/4" (6.35mm) exposed to allow keyhole slots to be easily mounted over the screw heads. After securing the unit using the keyhole slots, verify that the unit is level. Tighten top two screws so that they are flush with the wall. Use the four lower holes as a guide to mark and drill pilot holes. Use remaining four screws and four washers to complete installation of bed and mounting bracket. Insert washers over lower four screws. All SIX screws and four washers must be mounted to the chassis.
4. Ensure liner dispenser is free from damage. Remove key, unlock, and open liner dispenser lid. This will expose liner dispenser mounting holes. Line up dispenser mounting holes onto chassis and secure with the four screws provided. Close and lock the liner dispenser door.
5. Clean work area and inspect unit to ensure it opens and closes smoothly. Give "Operator Kit" and key to the facility operator. Replacement parts and additional liners can be purchased from your local distributor or by calling Koala at 888.733.3456 or 303.539.8300.

SPECIFICATION:

Baby changing station body shall be durable, injection-molded polypropylene. Design of unit shall be surface-mounted. Unit shall be equipped with a pneumatic cylinder for controlled opening and closing of bed. Bed shall be secured to metal mounting chassis with a concealed steel-on-steel hinge. No hinge structure shall be exposed on interior or exterior surfaces. Unit shall have mounting hardware included. Unit shall have Microban® antimicrobial embedded into plastic material on the changing surface. Unit shall conform to ANSI S117.1 Accessible and Usable Building and Facilities, ASTM F 2285-04 Standard Safety Performance Specification for Diaper Changing Tables for Commercial Use, ANSI Z535.4 Product Safety Signs and Labels, EN 12221-1:2008, ASTM G22 Antibacterial standards or local code if more stringent installation requirements are applicable for Barrier-Free accessibility. Unit shall comply with ADA regulations when properly installed. Bed shall have smooth concave changing area with a nylon safety strap and two hooks for bags or purses.

Unit shall have a built-in Liner Dispenser for use with 3-ply chemical free biodegradable bed liners, instructional graphics and safety messages in 4 languages. Optional Braille label is available. Unit shall be backed by manufacturer's 5-year limited warranty on materials and workmanship and include a provision for replacement caused by vandalism. Unit shall be manufactured in the U.S.A.

Baby Changing Station shall be model KB200-00 of Koala Kare Products, A Division of Bobrick, 6982 S. Quentin St., Centennial, CO 80112 USA, Tel: 1-888-733-3456 or 303-539-8359, Web: www.koalabear.com